

Affordable, Space-Saving Combination for a Wide Range of Speeds

Mini-Mover Conveyors now offers a variable-speed solution that combines precise, stable variable speed control, wide speed selection and smooth, quiet operation - all in a space-saving package ideal for tight spaces or designs.

The BMU Series brushless DC gearmotor is powerful, virtually vibration free in operation, and offers a very wide speed range selection from a single gearhead. The companion BMUD controller is quickly set up, with screwless connection points that allow easy wire insertion. Its intuitive user interface and large display allow users to quickly perform basic and extended function settings.

BLDC Gearmotor	Speed Range (fpm)	Load Capacity
005N	14 - 200	15 lbs
005N	200 - 263	5 lbs
010N	8 - 131	50 lbs
015N	5 - 88	150 lbs
020N	4 - 65	150 lbs
030N	3 - 43	150 lbs
050N	2 - 26	150 lbs
100N	0.8 - 13	150 lbs
200N	0.2 - 6.5	150 lbs

* Also available: IP 65-rated gearmotors for washdown applications



General Features

- Power input: 115/50-60/1 VAC and 230/50-60/1-3 VAC
- Output power 60W, 1/12 hp, 1.7 amps, IP40 rating
- Easy-to-read digital display on controller
- Programmable functions, with Dial Lock for frequent settings
- Supports external I/O signaling equipment
- Wide speed range
- Cooler operating temperatures vs. comparable AC motors
- Includes protective controller enclosure, 9-ft. controller-to-motor cable and 7-ft. power cord

Benefits

- Simple to set up
- No motor maintenance
- Longer motor runtime and life vs. brushed motors
- Friendly operating controls for all types of users
- 23% less energy usage vs. comparable 3-phase AC motor
- Extremely low vibration, ideal for vision systems, laser coding and ink-jet print applications
- Precise control of running speed, stops and starts
- Incorporates easily into tight spaces and compact designs

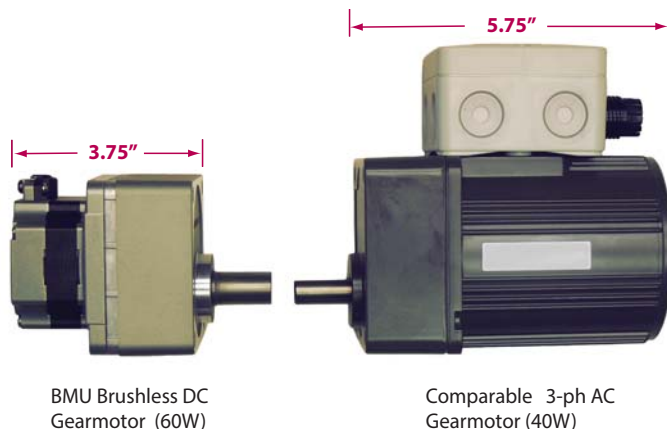

BMU Brushless DC Gearmotor (60W)

Comparable 3-ph AC Gearmotor (40W)

Mini-Mover Conveyor reserves the right to change / discontinue features or specifications without notice

Side-Mount Styles - Compact Group

Controls: Variable-speed digital controller with 9-ft. controller cable and 7 ft. AC power cord, included with gearmotor
 Options: IP65-rated gearmotors

I Style - Lite Series

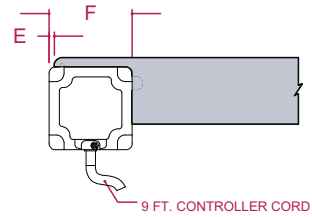
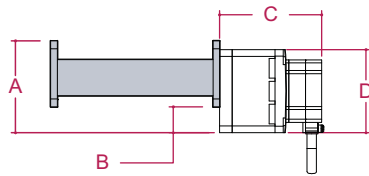

Gear Ratio	A	B	C	D	E	F
005N-020N	3.49"	0.99"	3.72"	3.15"	0.20"	3.15"
030N-100N	3.49"	0.99"	3.92"	3.15"	0.20"	3.15"
200N	3.49"	0.99"	4.12"	3.15"	0.20"	3.15"

S Style - LP Series

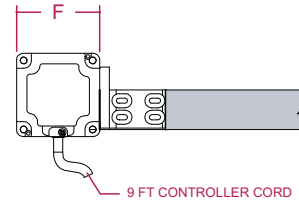
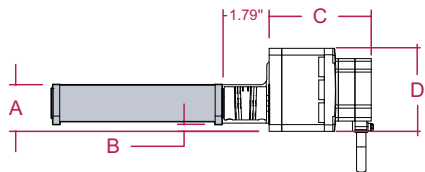

Gear Ratio	A	B	C	D	F
005N-020N	1.76"	0.26"	3.86"	3.15"	3.15"
030N-100N	1.76"	0.26"	4.06"	3.15"	3.15"
200N	1.76"	0.26"	4.26"	3.15"	3.15"

U-Style - Compact Group

Controls: Variable-speed digital controller with 9-ft. controller cable and 7 ft. AC power cord, included with gearmotor
 Options: IP65-rated gearmotors

U-Style - Lite Series

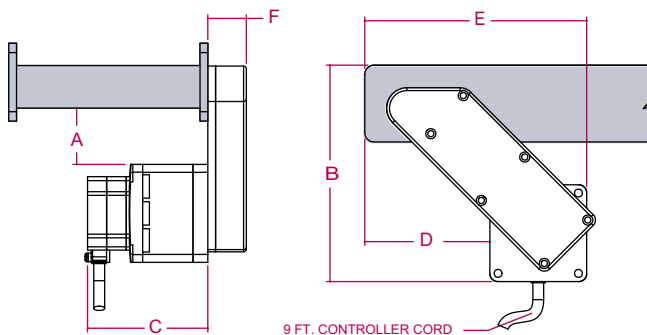

Gear Ratio	A	B	C	D	E	F
005N-020N	1.81"	7.04"	3.74"	4.07"	7.22"	1.24"
030N-100N	1.81"	7.04"	3.94"	4.07"	7.22"	1.24"
200N	1.81"	7.04"	4.14"	4.07"	7.22"	1.24"

U-Style - LP Series

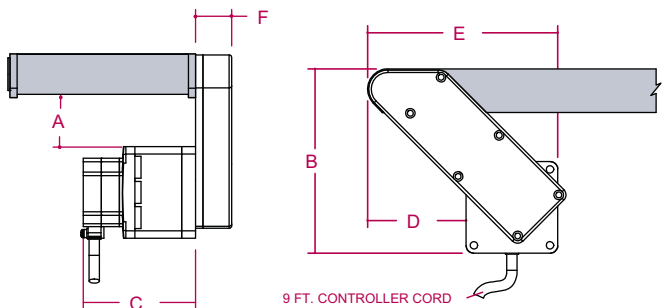

Gear Ratio	A	B	C	D	E	F
005N-020N	1.81"	6.34"	3.74"	3.40"	6.55"	1.24"
030N-100N	1.81"	6.34"	3.94"	3.40"	6.55"	1.24"
200N	1.81"	6.34"	4.14"	3.40"	6.55"	1.24"

Y-Style - Compact Group

Controls: Variable-speed digital controller with 9-ft. controller cable and 7 ft. AC power cord, included with gearmotor
Options: IP65-rated gearmotors

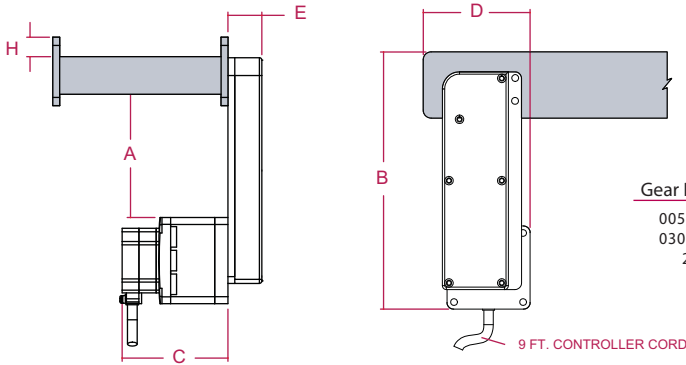

Gear Ratio	A	B	C	D	E	H
005N-020N	4.51"	9.74"	3.74"	4.05"	1.24"	0.72"
030N-100N	4.51"	9.74"	3.94"	4.05"	1.24"	0.72"
200N	4.51"	9.74"	4.14"	4.05"	1.24"	0.72"

Y-Style - Lite Series

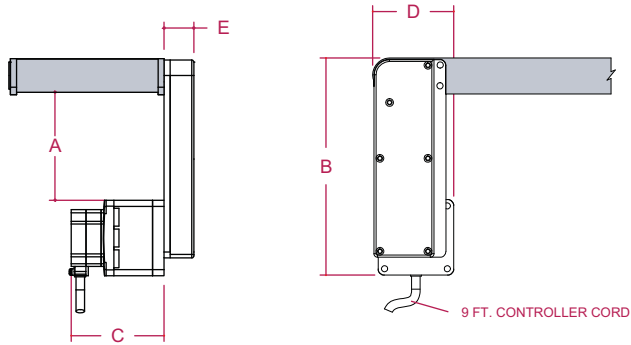

Gear Ratio	A	B	C	D	E
005N-020N	4.50"	9.04"	3.74"	3.37"	1.24"
030N-100N	4.50"	9.04"	3.94"	3.37"	1.24"
200N	4.50"	9.04"	4.14"	3.37"	1.24"

Y-Style - LP Series



Z-Style - Compact Group

Controls: Variable-speed digital controller with 9-ft. controller cable and 7 ft. AC power cord, included with gearmotor
Options: IP65-rated gearmotors

Z Style - Lite Series

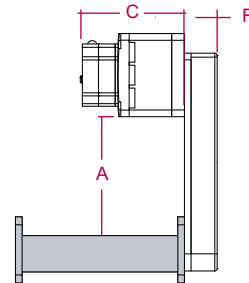

Gear Ratio	A	B	C	D	F
005N-020N	4.51"	9.44"	3.74"	4.05"	1.15"
030N-100N	4.51"	9.44"	3.94"	4.05"	1.15"
200N	4.51"	9.44"	4.14"	4.05"	1.15"

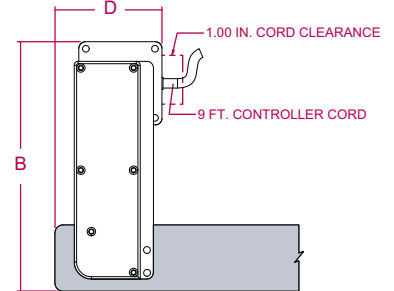

Z Style - LP Series

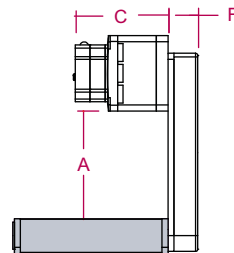

Gear Ratio	A	B	C	D	F
005N-020N	4.50"	9.14"	3.74"	3.37"	1.24"
030N-100N	4.50"	9.14"	3.94"	3.37"	1.24"
200N	4.50"	9.14"	4.14"	3.37"	1.24"

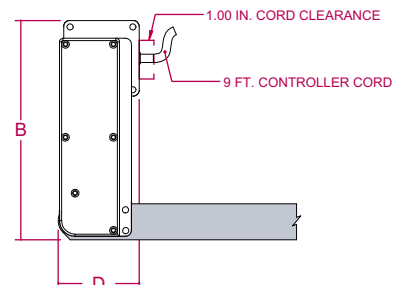

Remote-Mount (R) Styles - Compact Group

Controls: Variable-speed digital controller with 9-ft. controller cable and 7 ft. AC power cord, included with gearmotor
 Options: IP65-rated gearmotors

R Style - Lite Series

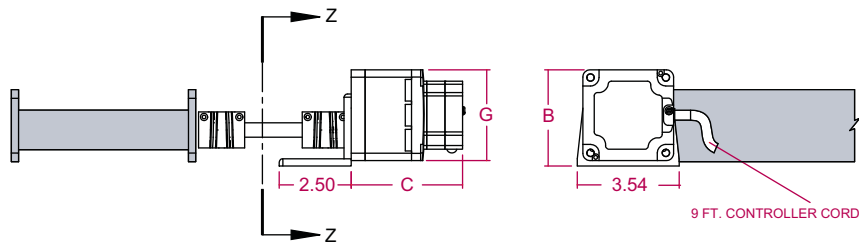

Gear Ratio	B	C	G	H	H min	H max
005N-020N	3.34"	3.72"	3.15"	1.25"	1.06"	2.06"
030N-100N	3.34"	3.92"	3.15"	1.25"	1.06"	2.06"
200N	3.34"	4.12"	3.15"	1.25"	1.06"	2.06"

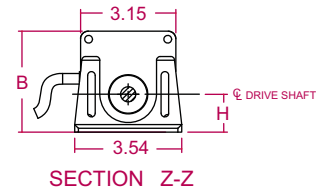

R Style - LP Series

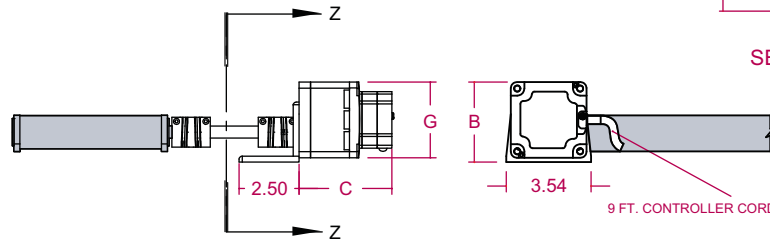

Gear Ratio	B	C	G	H	H min	H max
005N-020N	3.34"	3.72"	3.15"	1.25"	1.06"	2.06"
030N-100N	3.34"	3.92"	3.15"	1.25"	1.06"	2.06"
200N	3.34"	4.12"	3.15"	1.25"	1.06"	2.06"

Compact Group Drive Packages include Digital Controller & Cable

Digital controller features a wide range of functions to suit simple & complex applications

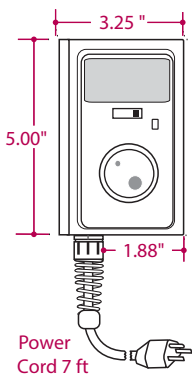

Slide on/off



Dial a speed



Push to set speed



Switch direction

TYPICAL OPERATING FUNCTIONS

- Motor Start/Stop
- Adjusting the operating speed
- Setting the operating speed
- Selecting the rotation direction
- Changing the indication
- Load holding function for output shaft

ADVANCED SPEED FUNCTIONS

- Indicating the operating speed when the speed reduction/speed increasing ratio is set
- Setting the acceleration/deceleration time
- Dial operation lock
- Speed setting for the 4-speed operation
- Speed limits setting

ADVANCED SIGNALING

- Validating the external operating signals
- External input/output signal allocation
- Setting the output alarms; many types available

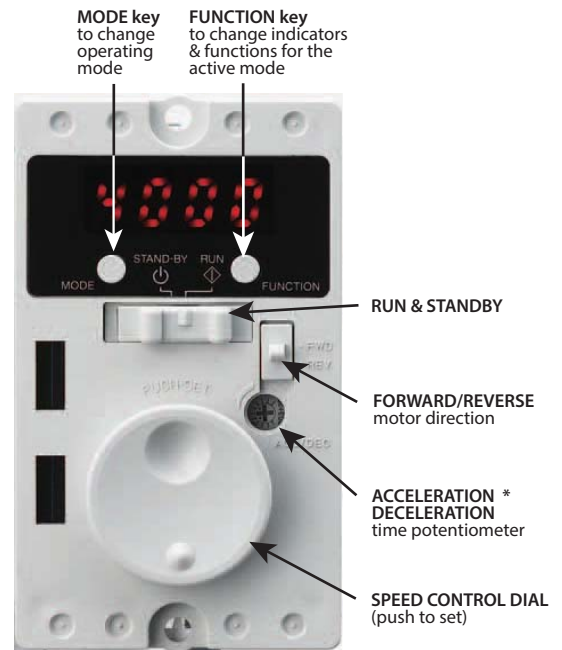

* Potentiometer accessed when faceplate removed

