

MINI-MOVER CONVEYORS

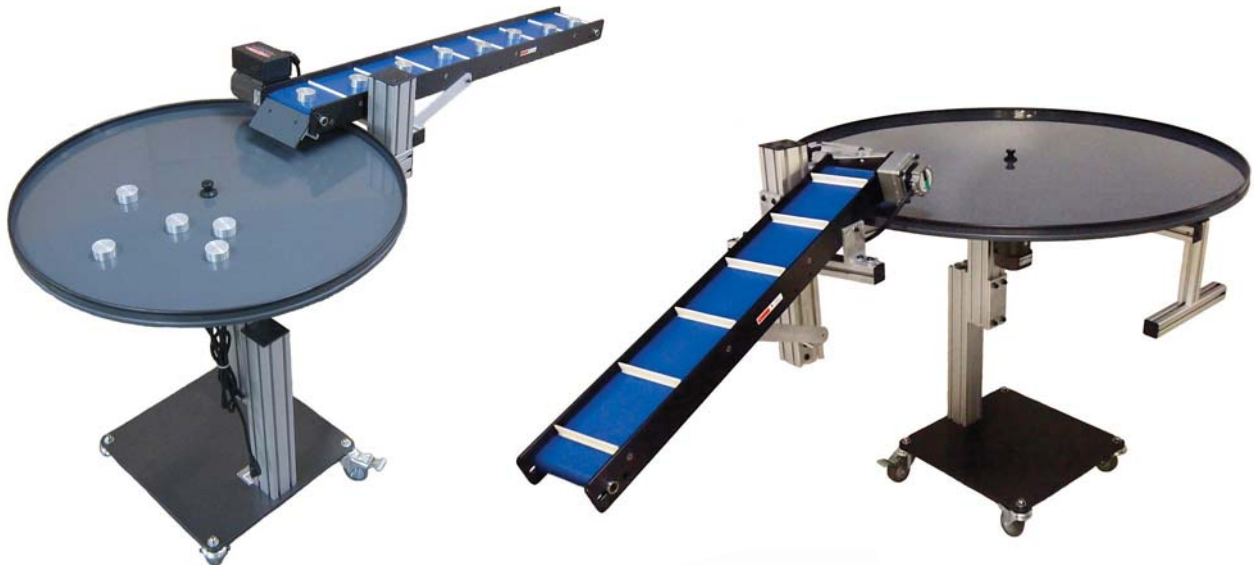

OWNER'S MANUAL UNI-MATE® Series



MADE IN THE U.S.A.

Visit us on the web at www.mini-mover.com

UNPACKING YOUR NEW UNI-MATE®

Please read this instruction manual before assembly or operation.

Congratulations. You have purchased a high-quality Mini-Mover Uni-Mate®. We suggest that you keep this manual and enclosed warranty information for future reference.

When Unpacking Your Uni-Mate®

Please note that the table unit will be partially disassembled to accommodate shipping. **(The conveyor is ready to install and run.)** Typically, each Uni-Mate® is crated and mounted onto a shipping pallet. Inspect all areas of the crate and pallet top, to ensure you locate all components, per the instructions below.

1. Do not invert the crate while unpacking.
2. To uncrate, first open the top, then open the sides.
3. Locate the tabletop:
 - a. For models 80-024 (24" dia.) and 80-032 (32" dia.) the tabletop will be packed inside the crate.
 - b. For Model 80-048 (48" dia.), the tabletop is stowed in a labeled flat box, which is bolted in between the crate's bottom and the top of pallet.
4. Unbolt the crate from pallet.
 - a. For models 80-024 or 80-032 shipment, pallet & crate can now be set aside for future shipment.
 - b. For Model 60-048 or custom tabletop size, remove the tabletop from box, unbolt crate from pallet and set packing materials aside for future shipment.
5. Remove conveyor and bagged components, and set aside.
6. Proceed to table assembly instructions on pgs. 5–9 of this manual.

Should any questions arise from the initial unpacking, assembly or operation following assembly, refer call Customer Service — 800-586-4585 — for immediate assistance.

Please Remember!

Retain the empty crate and packing materials, in the event the unit should require future repacking and shipment.



IMPORTANT!
**Read First, Before
Operating Unit**

Due to the variety of drive types, drive positioning & configurations, point-of-installation guarding is the responsibility of the end user.

As a result, the purchaser and/or end user of this product acknowledges that Whipple Enterprises Mini-Mover Conveyors cannot reasonably foresee the methods employed by the purchaser and/or end user regarding point-of-installation guarding; as a result, the purchaser and/or end user agrees to hold Whipple Enterprises harmless in the event that any claim is made against Whipple Enterprises as a result of the purchaser's and/or end user's activities with respect to point-of-installation guarding, or any other aspect of the installation and use of this product that is not in conformity with the provisions of your Mini-Mover Owner's Manual.

Contents

Unpacking Your New Uni-Mate®	i
Important Safety Instructions	2
Getting Started	3
Installation Sequence	3
Table (RTA) Components	4
A. Assemble Table	5
For Model 80-024 Only	5-7
For Models 80-032 & 80-048 Only	8-9
B. Attach Connection Assembly	10
C. Mount Conveyor	11
Uni-Mate® Operating Instructions	13
Controls Overview	13
A. Interconnect Table Controller and Indexing Timer	13
B. Prepare Controllers and Timer for Operation	14
C. Program the Indexing Timer	15
D. To Operate the Uni-Mate®	16
E. To Reverse Table Rotation	16
F. To Turn Uni-Mate® Off	16
Electrical Troubleshooting	16
Conveyor Information	17
Conveyor Maintenance	17
A. Unmount the Conveyor from Connection Assembly	17
B. Removing the Blank Siderail	17
C. Routine Conveyor Cleaning	18
D. Cleaning the Belting material	18
1. Routine Belt Cleaning	18
2. Periodic Tough Cleaning	18
E. Belt Replacement	18
F. Module Reassembly	18
Conveyor Component Descriptions	19
Conveyor Belt Tensioning	20
Conveyor Belt Tracking	20
Customer Service Information	21
Product Warranty	22

IMPORTANT SAFETY INSTRUCTIONS

To reduce the risk of fire, electrical shock and injury, always follow these basic safety precautions when using your Uni-Mate®.

1. Read and follow all instructions. Follow all warnings and instructions marked on your Uni-Mate®. Avoid jamming. Adjust your Uni-Mate® so as not to allow parts to jam or lock the table from rotating. This condition may cause serious damage not covered by warranty.
3. Do not place the Uni-Mate® on an unstable surface. A tip-over could cause serious damage to the unit or the operator.
4. Keep all loose clothing away from the unit while it is operating.
5. Ensure the collapsible handle or column is used to position or transport the assembled table to avoid possible instability or damage to the unit. **Do not use the tabletop as a means of moving the table; use the column or folding handle.**
6. Do not overload or unevenly load the unit. Damage or tip-over may occur.

The following precautions were written specific to Mini-Mover-supplied drives but are good general precautions for all electrical drives.

7. **Connect the Uni-Mate® components (table and conveyor) into a properly grounded power sources only.** Operating the unit at voltage or frequency not specified will void the product warranty. Check with a qualified electrician if you are not sure if the power source is grounded properly.
8. Do not overload the power source or use extension cords. This can increase the risk of fire or electrical shock.
9. Do not allow anything to rest on the power cord. Do not install the Uni-Mate® where people will walk on or trip over the power cords.
10. **Disconnect the unit from the power source before cleaning or maintenance.** Do not use liquid or aerosol cleaners. When necessary, clean using a soft cloth moistened with a mild detergent solution.
11. Do not locate the unit in areas where water or other fluids may splash on the motor or electrical control box.
12. The gearmotors are air cooled. Gearmotors should not be placed in a built-in enclosure unless proper ventilation is provided.
13. Do not operate the unit during an electrical storm. If your area gets frequent thunder storms, we strongly recommend connecting your unit's electrical connections into a power surge protector.
14. Disconnect the unit from the power source and consult a qualified service representative in any of the following situations.
 - A. When the power supply cords are frayed or damaged.
 - B. If liquid is spilled on the motor housing or electrical control box.
 - C. If the unit does not operate normally when following the basic operating instructions.
 - D. If the unit has been dropped or the motor, gearhead, or electrical control box is damaged.
15. Due to the variety of models, drive types, drive positioning & belt configurations, **point-of-installation guarding for the table and conveyor is the responsibility of the end user.**

Note: As a result, the purchaser and/or end user of this product acknowledges that Mini-Mover Conveyors/Whipple Enterprises cannot reasonably foresee the methods employed by the purchaser and/or end user regarding point-of-installation guarding; as a result, the purchaser and/or end user agrees to hold Whipple Enterprises harmless in the event that any claim is made against Mini-Mover Conveyors/Whipple Enterprises as a result of the purchaser's and/or end user's activities with respect to point-of-installation guarding, or any other aspect of the installation and use of this product that is not in conformity with the provisions of this Owner's Manual.

GETTING STARTED

Tools You Need for Assembly and Maintenance (Supplied with this Uni-Mate®)

TOOL	WHERE USED		
	Table	Connection Assembly	Conveyor
1/4" hex key	<ul style="list-style-type: none"> Base and support column. Cross-frame for model 80-032 and 80-048 only. Height adjustment for models 80-032 & 80-048 only. 	<ul style="list-style-type: none"> Column mount bracket (for horizontal arm) 	
3/16" hex key	<ul style="list-style-type: none"> Cross-frame for Model 80-024 Diverter arm height/angle VS controller and indexing timer mounting plates Height adjustment for Model 80-024 only. 	<ul style="list-style-type: none"> Column mount bracket (for mounting to column) Conveyor mount bracket Conveyor siderail attachment Mounting conveyor to bracket 	Belt tension lock screw (for later maintenance only)
5/32" hex key	Cross-frame and bearing block assembly (for potential maintenance only).		<ul style="list-style-type: none"> Discharge ramp Siderail access screws (for later maintenance only)
Clamping knob	Secures tabletop to cross-frame. <ul style="list-style-type: none"> Packed in tool kit for Model 80-024 Preinstalled on models 80-032 and 80-048 when shipped 		
Phillips head screwdriver, <i>small (not provided)</i>	<ul style="list-style-type: none"> Indexing timer, timing adjustment 		
Belt tensioning tool			Belt tracking & tensioning (for later maintenance only)

INSTALLATION SEQUENCE

A

Assemble Table



Model 80-024:
Instructions start on pg. 5
 Models 80-032 & 80-048:
Instructions start on pg. 8

B

Attach Connection Assembly

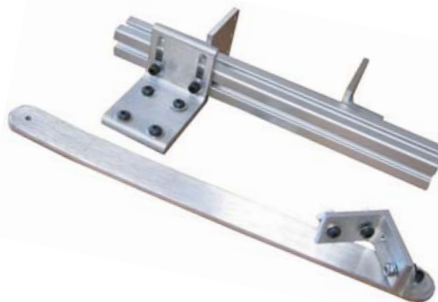

All models:
Instructions start on pg. 10

C

Mount Conveyor



All models:
Instructions start on pg. 11

TABLE (RTA) COMPONENTS

Fig. 1 below shows the locations of the main components that comprise a table unit supplied with the Uni-Mate® product. Note that the 80-024 (24" dia. model) has a single support column used for height adjustment. The 80-032 (32" dia.) and 80-048 (48" dia.) models use a telescoping column for height adjustment. .

- 1 **Tabletop.** Working surface of the table unit.
- 2 **Clamping Knob.** Secures tabletop to the drive hub. Includes a washer.
- 3 **Diverter-Arm Assembly.** The support mechanism provides horizontal stability and points of attachment for diverter arm paddle. The paddle acts to move parts from infeed to the center of tabletop for accumulation. Angle and height are adjustable.
- 4 **Support Column.** Provides the vertical support and height adjustment. Also used to move the table unit safely when a collapsible handle is not available or practical.
- 5 **Fence.** One-inch high, integral rim with in-feed cushion, for accumulation usage. Equipped as standard.
- 6 **Gearmotor.** Energy-efficient motor and gearhead combination. Can operate at a 1-3 rpm variable speed.
- 7 **Collapsible Handle (models 80-032 and 80-048).** Unfolds from beneath the unit for positioning and transport. It is not recommended to move unit by grasping the tabletop itself, which can damage the gearmotor.
- 8a **VS Controller.** Provides variable-speed controls, AC power cord and is pre-wired and preprogrammed to run with Indexing Timer. (Detailed operating instructions for the VS controller are supplied in a separate manual.)
- 8b **Indexing Timer.** Provides programmable start/stop control for the table; it includes a piggyback AC power cord to allow stop/start synchronization of the conveyor along with power supply.
- 9 **Base.** Provides a stable point of attachment for support column and locking casters.
- 10 **Locking Casters.** Four equipped as standard.

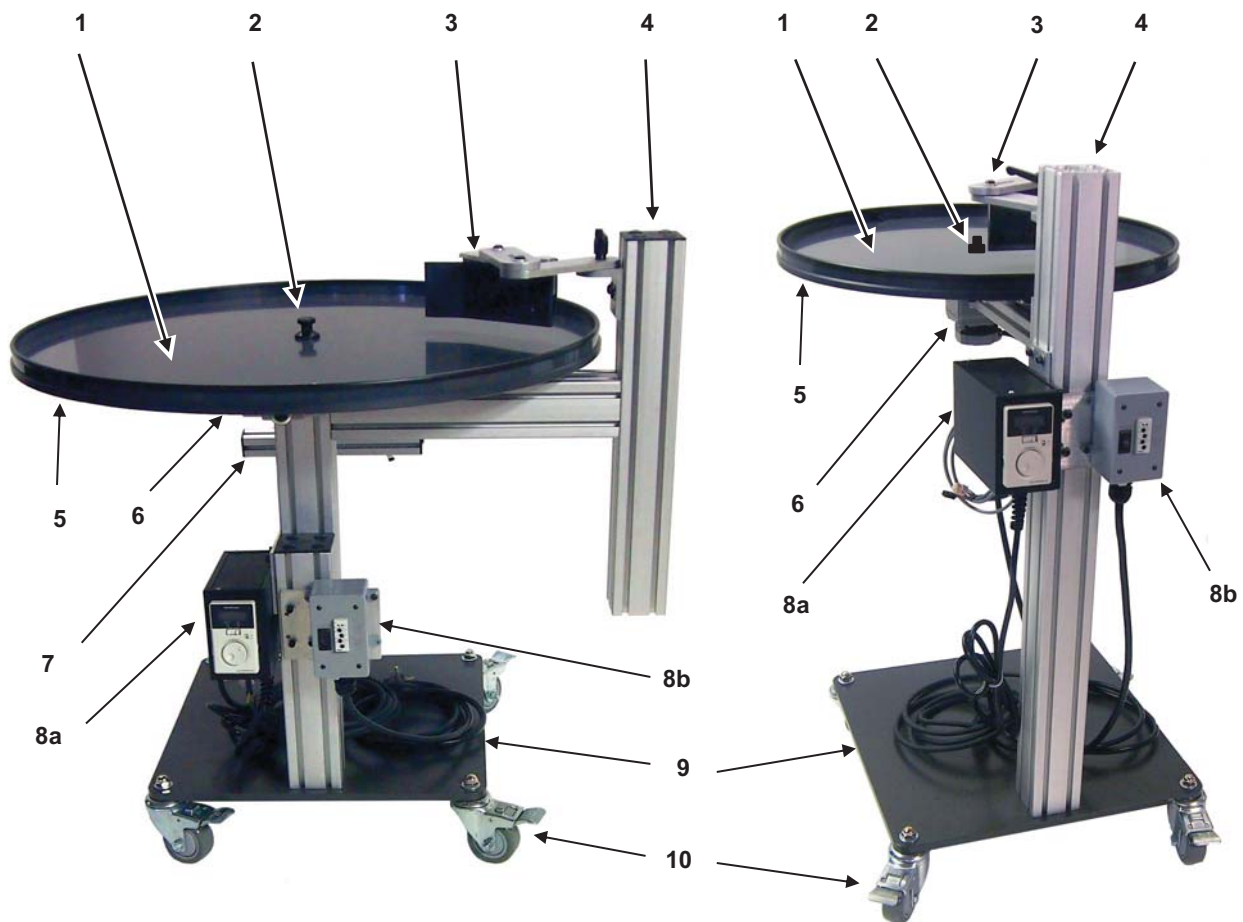

Models 80-032 & 80-048 (32" dia. shown here)

Model 80-024 (24" dia.) shown here

Fig. 1 - Table Components

For Model 80-024 Only

1. After unpacking, locate the base and column/cross-frame assembly (Fig 2). Orient the column to the base, as shown in Fig. 2a. Assemble using the four (4) SHCS. Use the 1/4" hex key.



Fig. 2
Column and base

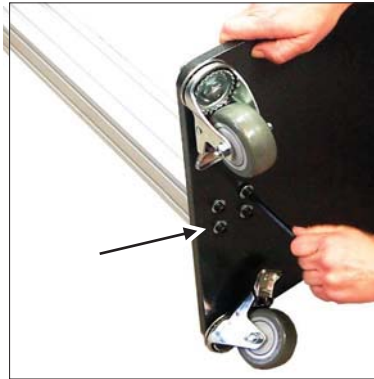

Fig. 2a
Attaching base

2. Set the base upright and slide on the cross-frame assembly per Fig. 3. Secure the plate in the T-slots, using the 3/16" hex key. Secure the cross-frame down far enough on the column to leave sufficient column clearance above it to mount the tabletop and conveyor above (approx. 6" or so). The unit is now ready for installation of the tabletop (Step 3).

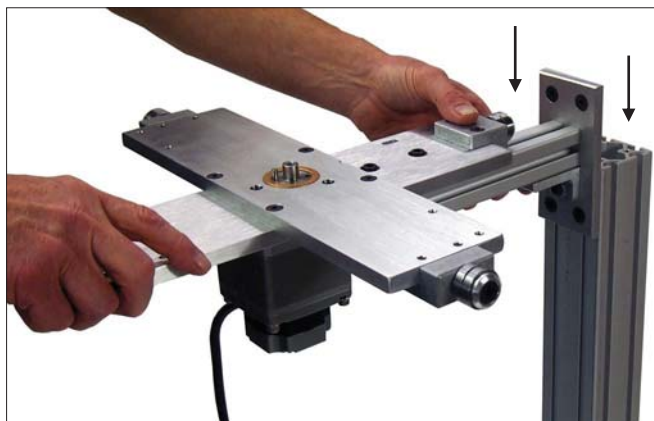

Fig. 3
Cross-frame assembly

For Model 80-024 Only

3. On the side and back (side opposite cross-frame) of the column mount the VS controller and indexing timer in the T-slots as shown in Fig. 5, securing the SHCS provided on the mount plates, using the 3/16" hex key. (These can be left loose and/or allowed to slide to the bottom of the column for now, for final adjustment later, after installation of connection assembly (Section B, pg. 10) and mounting the conveyor (Section C, pg. 11).



Fig. 5
Installing VS controller
and indexing timer

4. Install the tabletop to the cross-frame assembly, using the following steps.
 - a. Lower the tabletop onto the drive hub and carefully align with the drive pin.
 - b. Ensure the tabletop is seated evenly atop the drive hub, as shown in Fig. 6.
 - c. Install the clamping knob and its washer (supplied with your factory tool kit), and screw it down securely, but finger tight.

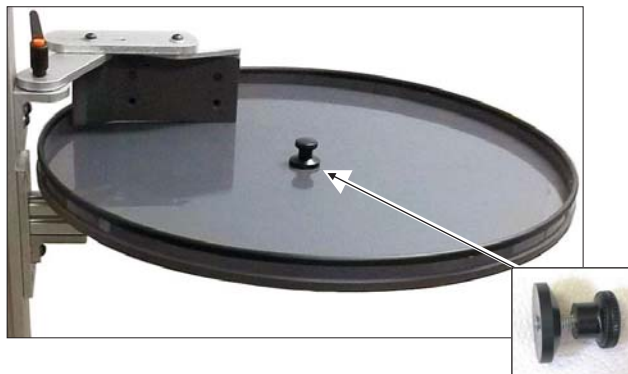

Fig. 6
Tabletop seated; diverter
arm installed on column

Note:

The diverter arm's upper paddle assembly can be kept loose now, for final adjustment after the conveyor is mounted.

5. Install the diverter arm assembly to the support column, as shown in Fig. 6 above. Use the 3/16" hex key. Leave upper arm loose for now, until final adjustment after conveyor is mounted (Section C, pg. 12).

For Model 80-024 Only

6. Assembly of the Model 80-024 is complete. VS controller and indexing timer should be oriented on the column T-slots as shown in Fig. 7 below. The Indexing timer should be allowed to slide loosely down the column, to ease the next installation steps, per Fig. 7a below. It can be given final adjustment after conveyor is mounted (Section C, pg. 12).



Fig. 7
Assembled 80-024 table

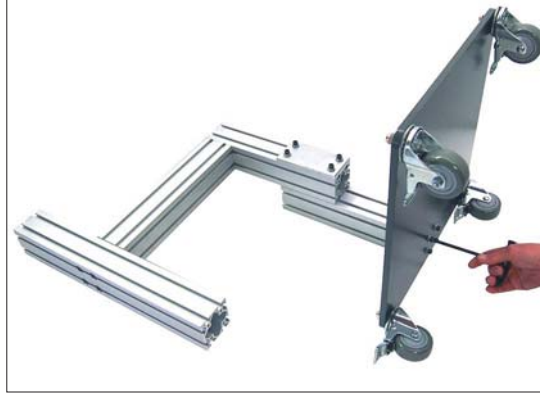

Fig. 7a
Allow the timer to slide out of the way until later adjustment.

7. Proceed to Section B, "Attach Connection Assembly" on pg. 10.

For Models 80-032 and 80-048 Only

1. After unpacking, locate the base and column assembly. Orient the column to the base, as shown in Fig. 8. below. Assemble using the four (4) SHCS. Use the 1/4" hex key.

**Fig. 8**
Base & column

2. Set the base and column assembly upright. Orient the cross-frame/motor assembly to the column assembly, as shown in Fig. 9 and 9a below. Assemble using the four (4) SHCS. Use the 1/4" hex key.

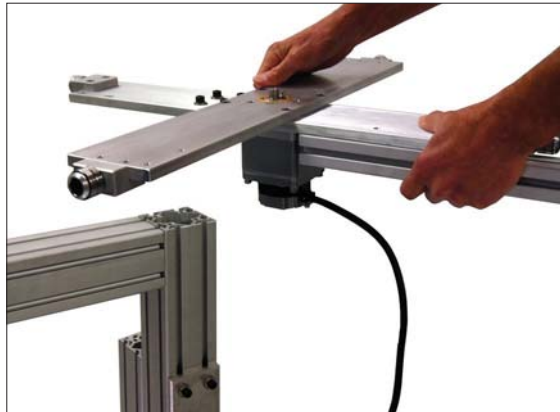
**Fig. 9**
Cross-frame assembly**Fig. 9a**
Cross-frame installed

For Models 80-032 and 80-048 Only

3. Install the tabletop to the cross-frame assembly, using the following steps. Fig. 10 shows the completed result.
 - a. Remove the clamping knob and washer from the drive hub, which is located in the center of the cross-frame (see arrow in Fig. 10).
 - b. Lower the tabletop onto the drive hub and carefully align with the drive pin.
 - c. When the tabletop is seated atop the drive hub, reinstall the clamping knob finger tight to secure it.
4. Install the diverter arm assembly by sliding down the T-slot nearest the tabletop, as shown in Fig. 10. Use the 3/16" hex key. (Leave paddle adjustment loose until adjusted later in this guide.)

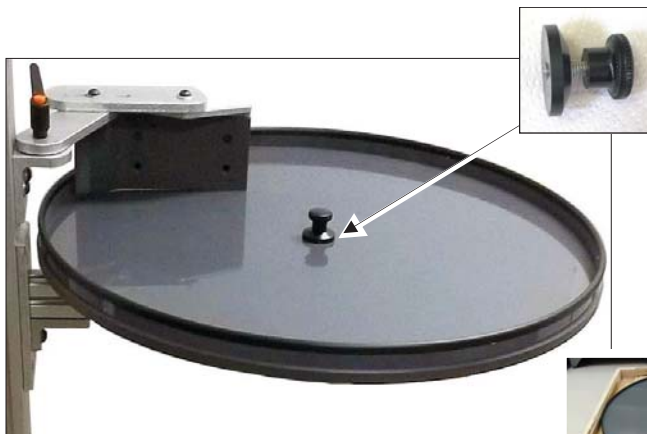

Fig. 10
Tabletop seated, clamping knob seated and diverter arm installed

Important Note for 48" dia. Tabletops

The tabletop for Model 80-048 is packed atop the pallet. Access it by first unbolting and removing the shipping crate.



5. On the bottom section of the telescoping column, the side opposite the folding handle, mount the VS controller and Indexing timer in the T-slots as shown in Fig. 11. Secure them with the SHCS provided on their respective mounting plates, using the 3/16" hex key.



Fig. 11
Install the VS controller and Indexing timer

6. Proceed to Section B, "Attach Connection Assembly" on pg. 10.

For All Uni-Mate® Models

1. With the horizontal brace in hand, slide the column mount bracket down the T-slots on the table's column as shown in Fig. 12 below. Lower the horizontal arm to the approximate height you want for the conveyor, per Fig 12a below, with final height and angle adjustments to be made in Section C, pg. 11.

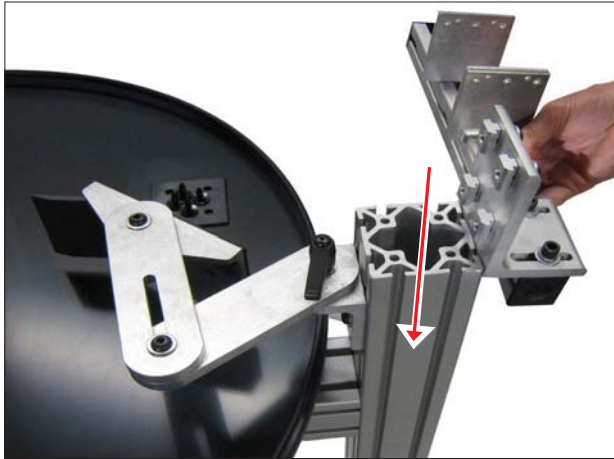

Fig. 12
Slide column mount bracket
down T-slots

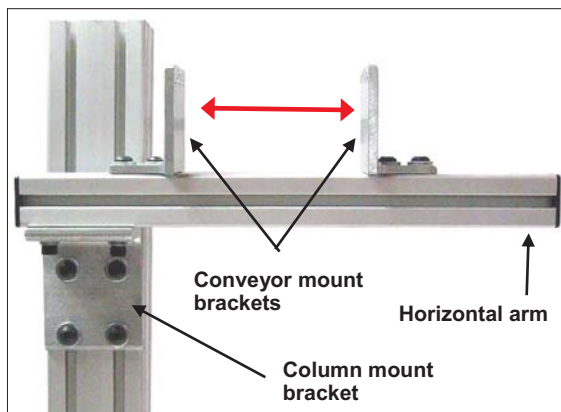

Fig. 12a
Orientation of connection
assembly components

2. Install swing-arm bracket, sliding down the column T-slot. (Use the one closest to connection assembly on Model 80-024; either T-slot works for models 80-032 and 80-048.) Let slide down toward the column bottom until Section C, pg. 11, Step 3, when the arm-end is connected to conveyor.

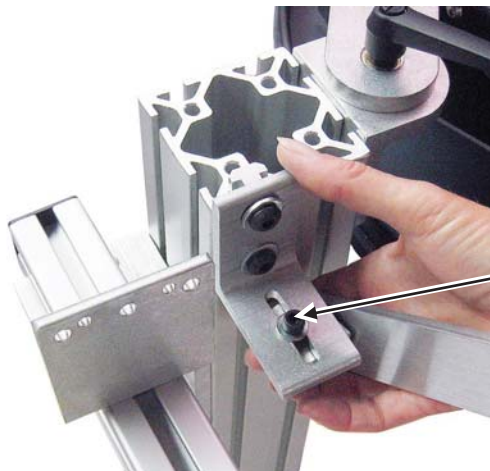
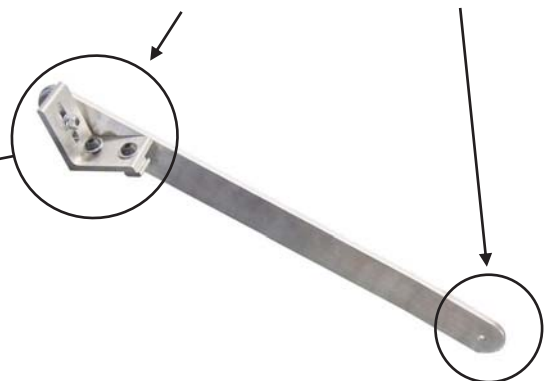

Fig. 13
Swing-arm bracket and arm-end



3. Proceed to Section C, "Mount Conveyor," on pg. 11.

For All Uni-Mate® Models

1. Unpack the conveyor, and install the discharge ramp with the two (2) supplied SHCS and the 5/32" hex key. Otherwise, **the conveyor is ready to run out of the shipping carton.** (You do not need to make any belt or gearmotor adjustments at this time. Conveyor instructions in this guide, on pp.17-20, pertain to subsequent maintenance activities.)

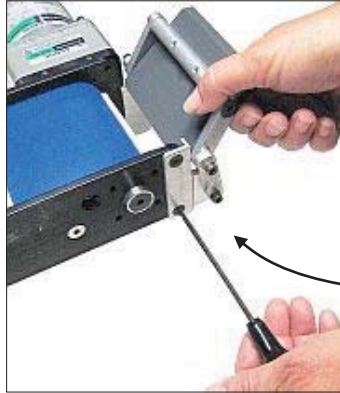

Fig. 14
Install discharge ramp on conveyor



2. Lower the conveyor between the loosened conveyor mount brackets (per Fig. 12a on pg. 10). Use only one (1) SHCS on each siderail, which allows conveyor rotation to the desired angle on the bracket. Fasten just finger tight for now; it can be tightened after attaching the arm-end of the swing-arm in Step 3 below.

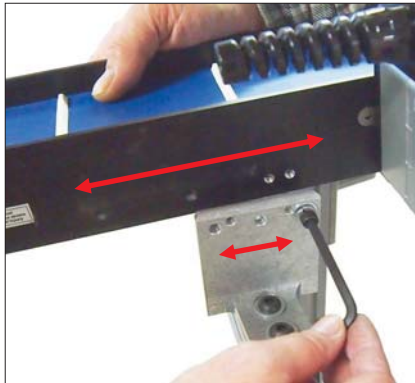

Fig. 15
Attach conveyor to mount bracket

Note: Bracket and siderail contain many holes to allow for the desired positioning.

3. Attach the arm end of the swing arm to the conveyor siderail with one (1) SHCS. Then make adjustments to the other connection components as shown below to achieve the desired conveyor height and discharge angle to the table.

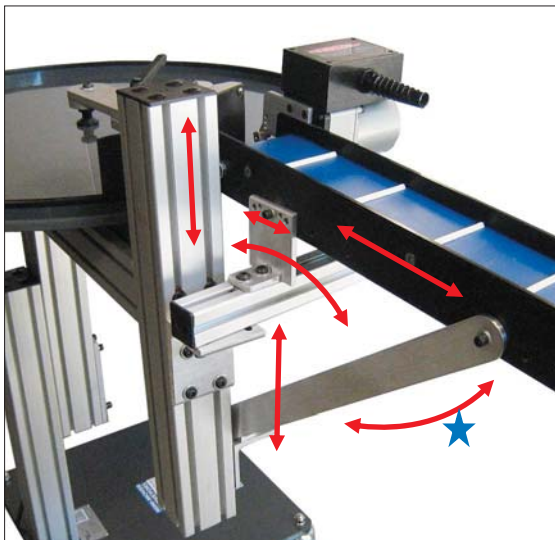

Fig. 16
Make final conveyor angle and positioning adjustments

★ *Note: Depending on the Uni-Mate® model and conveyor length, the conveyor's infeed angle adjustments can range about $\pm 10^\circ$ up or down from level.*

For All Uni-Mate® Models

- Adjust the diverter arm, using the quick-adjust handle and 3/16" hex key, to suit the size of product you are transporting and accumulating from conveyor to table.

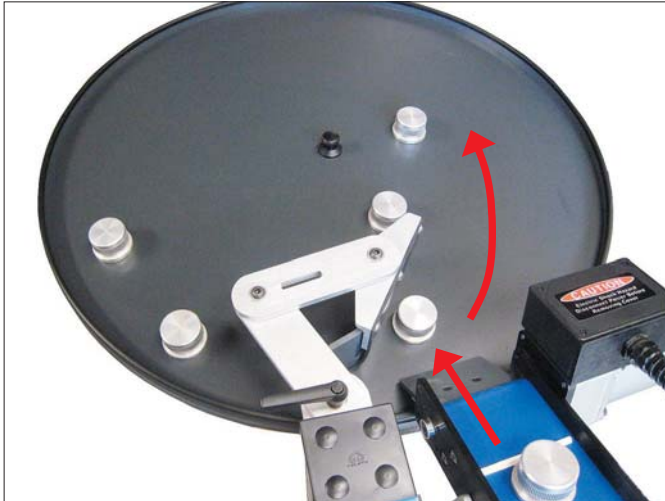

Fig. 17
Adjust the diverter arm

Note: This figure shows adjustment made for a table set for standard counter-clockwise (CCW) rotation.

(If table rotation is reversed, simply reverse the arm and paddle adjustments accordingly.)

SET-UP TIPS

- Angle conveyor down from table to allow fluid drain back into the machining center.
- Use Indexing timer to start/stop conveyor, to allow maximum fluid drain back into machining center.
- As parts are finished, have them air-knifed to remove chips and excess fluid.

- Make final adjustments to the conveyor, VS controller and Indexing timer positions on the assembled Uni-Mate® unit to suit your application and preferences.



Fig. 18a
Model 80-024



Fig. 18b
Models 80-032 (shown) and 80-048



NOTE: For maximum stability prior to operation on all Uni-Mate® models, point each castor on the base or base extender at a 45° angle from each edge. Lock all four casters.

- Proceed to "Uni-Mate® Operating Instructions" on pg. 13.

UNI-MATE® OPERATING INSTRUCTIONS

For All Uni-Mate® Models

CONTROLS OVERVIEW

Your Uni-Mate® comes equipped with a gearmotor for the table and a gearmotor for the conveyor. The standard factory controls for these gearmotors are described and shown below:

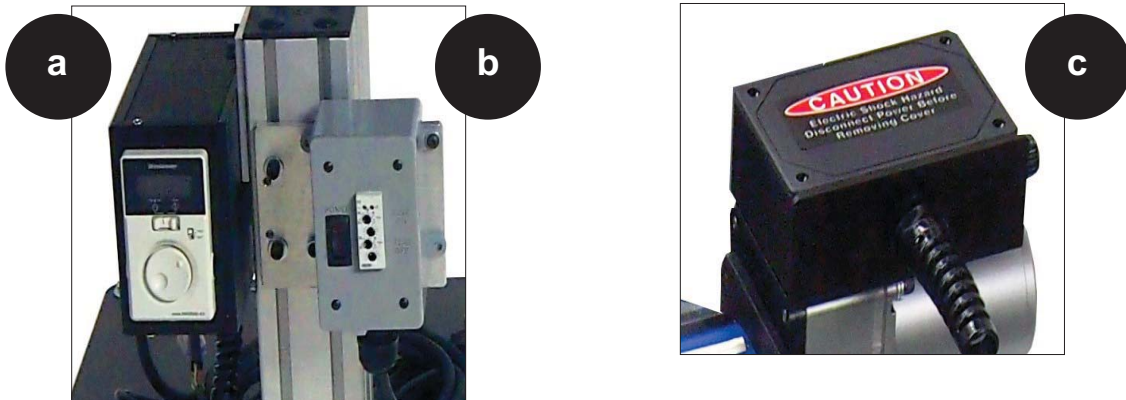

Controls That Mount on Table Column

- a. **Compact VS controller:** This offers a speed range of 1 to 3 rpm. Comes with a 7-ft. AC power cord. (A separate manual is provided for the VS controller's operation, features and programming details.)
Note: The VS controller is preset at the factory for use with the Indexing timer. However, the user may change the VS controller preset from "On" to "Off," which allows conventional variable-speed operation. See instructions in Step B-2-b on pg. 14 to turn indexing to "Off."
- b. **Indexing timer:** This timer is standard equipment and comes with a 7-ft. AC power cord. When connected to the VS controller, it provides programmable stop/start action. The power cord includes a "piggyback" plug to allow the conveyor's AC power cord to be connected and synchronized, via the timer, with the table's indexing movement.

Controls that are Factory-Mounted on Conveyor

- c. **Fixed-Speed Control:** This provides simple On/Off functions and conveyor connection to AC power. The conveyor can operate at fixed speed, independent of the table's movement, or it can be powered by and synchronized with the Indexing timer (using the piggyback plug).

A. Interconnect Table Controller and Indexing Timer

1. **On the table unit:**
Snap together the white and black connectors between the gearmotor and VS controller, as shown in Fig. 19.
2. **On the table unit:**
Connect the clear plastic connector (on dark gray wire) from the VS controller to the Indexing timer, as shown in Fig. 20.
Note: If you do not wish to install or use the Indexing timer at this time, omit this step.
3. Proceed to Step B-1 on pg. 14 for the next controller/timer preparation actions.

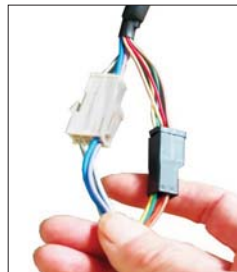

Fig. 19
Table gearmotor
to VS controller
connections



Fig. 20
VS controller to
Indexing timer
connection

UNI-MATE® OPERATING INSTRUCTIONS

For All Uni-Mate® Models:

B. Prepare Controllers and Timer for Operation

1. On the table unit:

Plug in the VS controller to a properly grounded, **non-switched** AC power source. (*Do not plug the controller into the timer.*) The VS controller also is preset at the factory to be used with the indexing timer.

2. On the table unit:

- a. If you plan to use Indexing timer functions, plug it into a properly grounded AC power source.

Now skip to Step 3a below.

- b. **If you do NOT plan to use the Indexing timer right away, it should be programmed “Off” in the VS controller as follows.**

- i) Remove faceplate, and locate Mode and Function buttons in the display area, as shown in Fig.21 (see white arrow).
- ii) Press the Mode button repeatedly until code “Par” appears.
- iii) Press Function button repeatedly until code “ioEn” appears.
- iv) Push the large center wheel.
- v) Now turn this wheel to change the setting from “On” to “Off.”
- vi) Reset the driver by unplugging the VS controller. Wait for the display to go dark before restoring power.

Note 1: If the Indexing timer will be unused for a long period, it can be uninstalled and stored until needed.

Note 2: To reset the indexing state back to “On,” repeat the above sequence and reverse Step 2-b-v.

Then skip to Step 3b below.

3. On the conveyor unit:

- a. For synchronized indexing with the table, plug the conveyor’s AC power cord into the piggyback socket on the Indexing timer, as shown in Fig. 22.

- b. For operating speed independent of table, plug the conveyor’s AC power cord into a properly grounded power receptacle.

Note: The conveyor can run independently at fixed speed even if the table is set to run with the Indexing timer “On.”

4. Proceed to Indexing timer programming instructions on pg. 15.



Fig. 21
Removing VS Controller’s faceplate



Fig. 22
Piggyback socket on indexing timer cord

UNI-MATE® OPERATING INSTRUCTIONS

For All Uni-Mate® Models:

C. Program the Indexing Timer

The Indexing timer's timing panel consists of two (2) pairs of control wheels that are turned using a small Phillips head screwdriver. These controls allow independent control of both the "On" and Off" times. Each pair of wheels ("Time 1" ON pair and the "Time 2" OFF pair) are shown in Fig 23.

- "Coarse" settings (to set time in days/minutes/seconds) - 1 second to 100 days
- "Fine" settings (fractions of seconds up to 1 second) - 0.1 second to 1 second

Very small imprinted arrows are located on the face of each wheel to show its set position (Fig. 24).

(Power switch can be either Off or On while the timing is being set.)

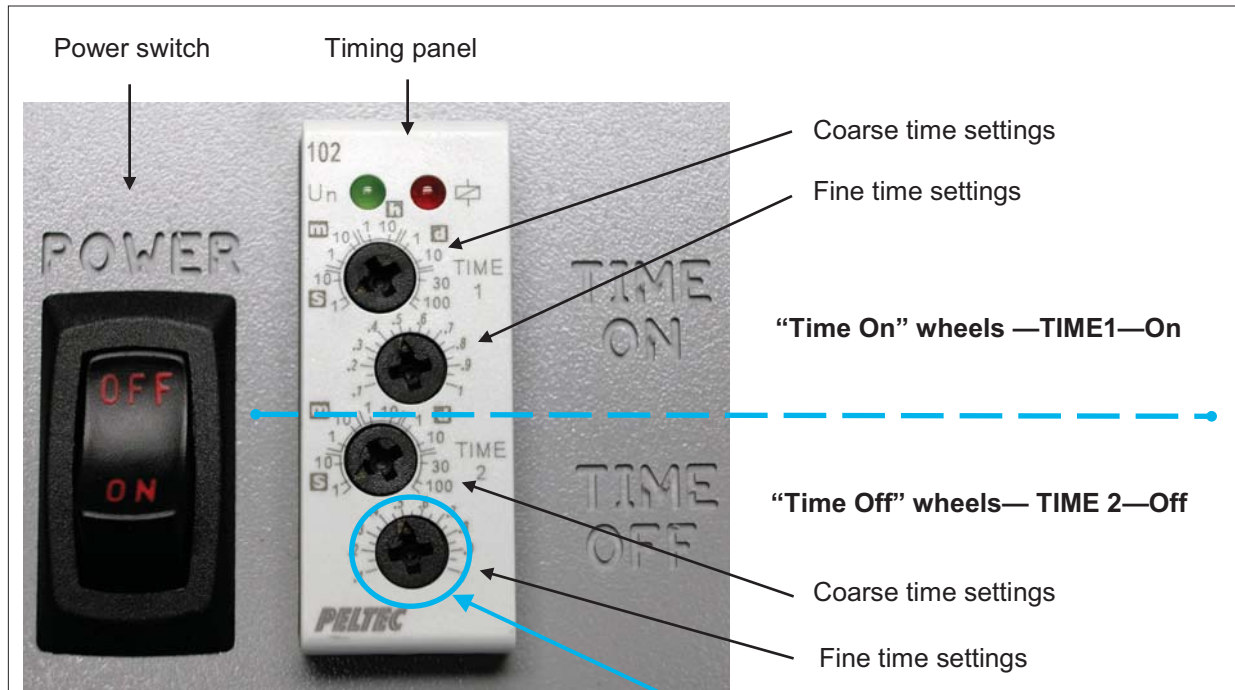

Fig. 23 - Indexing timer controls

1. On the TIME 1 pair of wheels, use the screwdriver to set the time duration for connected units to be ON.
2. On the TIME 2 pair of wheels, use the screwdriver to set the time duration for connected units to be OFF.

Timing Example:

Parts are dropping from the machine to the conveyor in 5-minute intervals. To provide separation as parts are moved down the conveyor to the table:

- Set TIME ON to 2.5 seconds
- Set TIME OFF to 5 minutes

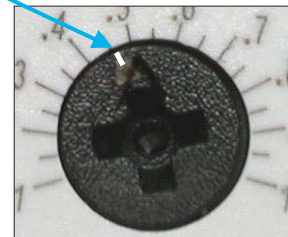

Fig. 24
Small imprinted arrow

3. Proceed to pg. 16 to begin operating the Uni-Mate®.

UNI-MATE® OPERATING INSTRUCTIONS

For All Uni-Mate® Models:

D. To Operate Uni-Mate®

1. Ensure the VS controller and Indexing timer are individually connected to a properly grounded AC power source per prior steps in this guide. **Do not attempt to power the VS controller via the piggyback plug in the Indexing timer's AC power cord.**
2. Ensure conveyor is connected either to the piggyback plug in the Indexing timer (synchronized with table) or to its own, grounded AC power source (independent fixed speed) per pg. 14 of this guide.
3. Switch the VS controller to "RUN" (On) and the Indexing timer to "On."
4. Switch the conveyor's power switch to "On."

E. To Reverse the Table Rotation From Clockwise (FWD = Factory Default)

1. Turn the Indexing Timer power switch to "Off."
2. Turn the VS controller slide switch to "STAND-BY" (Off).
3. Flip the Rotation Direction Switch on the VS controller to the "REV" position.
4. Reposition the diverter arm on the table to accommodate product accumulation in the counterclockwise direction (review Fig. 17 on pg. 18 if needed)

F. To Turn Uni-Mate® Off

1. Switch the conveyor's power switch to "Off."
2. Switch the VS controller to "STAND-BY" (Off) and the Indexing timer to "Off."

ELECTRICAL TROUBLESHOOTING

Upon initial unpacking and operation, it is recommended that you inspect and test the condition of the main electrical components to ensure smooth operation. In the event that any connections have loosened during shipment, the following are frequently checked areas. If you continue to experience problems with your unit than cannot be resolved using the following actions, call our Customer Service Dept. at 800-586-4585 for immediate assistance.

COMPONENT	SYMPTOM	START CONDITION	ACTION
Fixed Speed Control	No indicator light. Conveyor will not run.	Power connected to AC. Power switch ON.	Unplug & check fuse connection. Check wire connections. Replace fuse if needed.
Fixed Speed Control	Indicator light ON. Conveyor will not run.	Power connected to AC. Power switch ON.	Unplug & check connections inside control box.
Fixed Speed Control	Indicator light ON. Conveyor will not run.	Power connected to piggyback. Power switch is ON.	Ensure Indexing timer's power switch is ON.
Indexing Timer	No green/ON indicator light.	Power connected to AC.	Unplug and use another AC outlet to check power source.
Indexing Timer	Green indicator light is ON. Table and/or conveyor will not run.	Power connected to AC. Timer relays not clicking. VS controller and conveyor connected to Indexing timer.	Check wheel settings of Indexing timer to verify it is timed to run. If time settings are good, check wire connections.
Indexing Timer	Green indicator light is ON. Table runs continuously, will not index.	Power connected to AC. VS controller connected to Indexing timer.	Check wheel settings of Indexing timer to verify it is timed to index. Verify VS controller is programmed for index function to be On (pg. 14).
VS Controller	No indicator/display light. Table will not run.	Power connected to AC. Power switch set to RUN.	Unplug and use another AC outlet to check power source. Unplug & check fuse connection. Check wire connections. Replace fuse if needed.
VS Controller	Indicator/display light is ON. Table will not run.	Power connected to AC. Power switch set to RUN.	Check On/Off settings of Indexing timer to verify it is timed to run. If time settings good, check wire connections. Refer to VS controller manual if above steps do not fix problem.

CONVEYOR INFORMATION

SECTION INTRODUCTION

This “Conveyor Information” section contains only those maintenance instructions for the Lite Series conveyor or when it is functioning as part of the Uni-Mate®. It is slightly hardware-modified to suit this product bundle.

While the Uni-Mate® conveyor has all the capabilities of a standard Lite Series conveyor (if chosen to be used later on a stand-alone basis), the information provided in this manual is limited to those features and procedures that are recommended for use in conjunction with Uni-Mate® operation.

For full Owner’s Manuals for the standard Lite Series (Integral Drive) or Lite Series (O/UM Drive), call Customer Service at 800-586-4585, or download a PDF copy at: www.mini-mover.com/service-and-parts.

Operating & Maintaining the Uni-Mate® Conveyor

1. Please review and observe the Unpacking and Safety instructions given pg. i and pg. 2 of this manual.
2. All tools needed to install and maintain the conveyor are listed on pg. 3.
3. The conveyor’s belt is ready to run, right out of the shipping carton. Proper tension and tracking were made at the factory before shipment. Proper tension may appear slack, so note how much is normal. Do NOT tighten prior to initial use.

***Tip:** From the underside of the module, push the belting upward toward the bedplate to establish the normal amount of “slack” for the belt material on your unit. Use this as your tension benchmark for future belt maintenance. A properly adjusted belt prolongs component life. (See Belt Tensioning on pg. 20.)*

4. Protect the conveyor from water or other liquids that could damage the gearmotor or electrics.
5. The conveyor is equipped with a Fixed/speed control box equipped with an On/Off switch. To ensure correct connection for Uni-Mate® operation, refer to the “Operating Instructions” section on pp. 13-16.

CONVEYOR MAINTENANCE

Utilizing an integral gearmotor drive, rugged aluminum frame, sealed bearings, and reinforced endless belting, this Mini-Mover conveyor is designed for years of trouble-free service. To maximize belt life and reduce the risk of damaging the bedplate and siderail surfaces, remove debris and clean the conveyor belt on a regular basis. Removal of the blank siderail is important for thorough access to clean the needed surfaces.

A. Unmount the Conveyor from Connection Assembly

(See figs. 15 and 16 on pg. 11)

1. Remove the SHCS from the swing arm.
2. Remove the SHCS that connects each conveyor siderail to the conveyor mount bracket.

B. Remove the Blank Siderail

(See figs. 26a and 26b on pg. 19)

1. Turn the unit off (On/Off Switch) and disconnect the conveyor drive from the electrical power source.
2. Remove the unit from the stand or other mounting, and place it on a flat, stable surface.
3. Locate the belt tension lock screws (see figs. 26a and 26b, #5). Loosen, but do not remove, using a 3/16” hex key.
4. Turn the unit on its side with the drive package facing down.
5. Using a 5/32” hex key, remove the maintenance access screws (Fig. 26a and 26b, #4b).
6. Lift the siderail straight up to access the belt and bedplate, and set aside.

CONVEYOR MAINTENANCE

C. About Routine Cleaning

1. Follow the procedure above to remove the blank siderail.
2. Slide the belt off both pulleys and set aside.
3. Using a brush (do not use a wire brush) or cloth, remove any debris or other bulk material from the inside surface of the drive siderail and all surfaces of the blank siderail.
4. Use a mild solution of detergent and warm (not hot) water-moistened cloth to clean all surfaces of both siderails, bedplate and pulleys. **Caution:** Do not allow liquid to enter the motor housing.
5. Proceed to D-1, Routine Belt Cleaning.

D. Clean the Belting Material

1. Routine Belt Cleaning

- a. For polyurethane & PVC belting materials: Use a mild solution of detergent and warm (not hot) water-moistened cloth to clean all surfaces of both sides of the belt.
- b. For belting made of fabric or specialty textured surfaces, use a soft to medium bristle brush (not a wire brush) to work the above-mentioned detergent solution into the textured surface, and rinse when completed.

2. Periodic Tough Cleaning

Between routine module or belt cleaning intervals, or to clean tougher debris or buildup, the following are suggested:

- **For occasional wipedown:** Use “409” or equivalent solution. Wet surfaces using a moistened cloth. Let stand for 10 minutes, scrub with cloth and rinse with water-moistened cloth.
- **For infrequent cleaning:** Cleaning solvents may be considered for very tough debris, but first, please consult factory for recommended agents to use on the conveyor.

E. Replace the Belt

1. Follow the procedure on pg. 17 to remove the blank siderail.
2. Slide the old belt off the pulleys and discard.
3. Slide the new belt over the pulleys and follow the assembly procedures in Step F below.

F. Reassemble the Conveyor

1. Position the belt on the pulleys at both ends of the conveyor.
2. Position the blank siderail to align the siderail to maintenance access screw holes, and the bearing adaptors to the pulley bearings.
3. Insert and hand tighten the siderail to maintenance access screws.
4. Using a 5/32” short handle hex key, tighten the maintenance access screws until the key handle flexes approximately 1/2.”
5. Proceed to the belt tensioning procedure on pg. 20.

Fig. 25 - Bearing Alignment Pin Positions

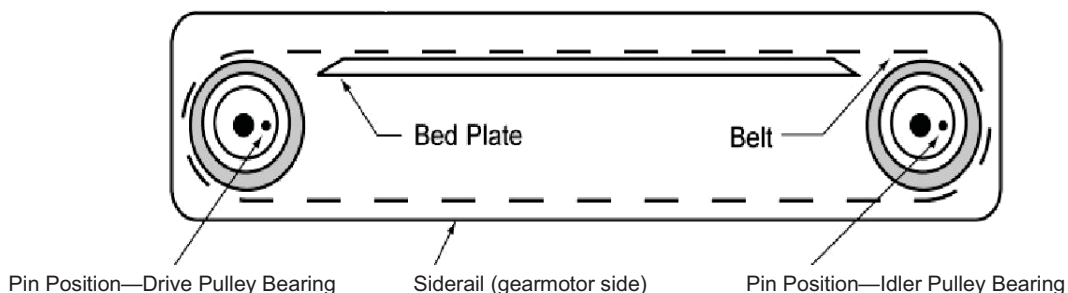

CONVEYOR COMPONENT DESCRIPTIONS

These illustrations provide location of conveyor controls, maintenance access screws, gearmotor, gear-head and belt adjustment points.

- 1 **Accessory Mounting Holes.** Tapped 10-32.
- 2 **Drive Pulley Lock Screw.** Locks drive pulley in position after belt tracking adjustment is completed. (Located on opposite, or blank, side of the drive pulley.)
- 3 **Pulley Bearing Positioning Pins.** Locks position to prevent bearing adapter rotation.
- 4a **Mounting Holes.** Drilled and tapped 1/4 -20 to accept optional mounting bracket or stands.
- 4b **Maintenance Access Screws.** Allow attachment of standoffs, if equipped, and siderails to bedplate. Use 5/32" hex key.
- 5 **Belt Tension Lock Screws.** Locks idler pulley in place after adjusting belt tension. Use 3/16" hex key.
- 6 **Gearmotor.** Fractional HP. Includes motor and gearhead. Lubricated for life.

Fixed-Speed Controls

- 7 **On/Off Switch.** Switches power to motor capacitor and winding.
- 8 **Electrical Control Box.** Houses motor capacitor, wiring, On/Off switch, indicator light and fuse holder.

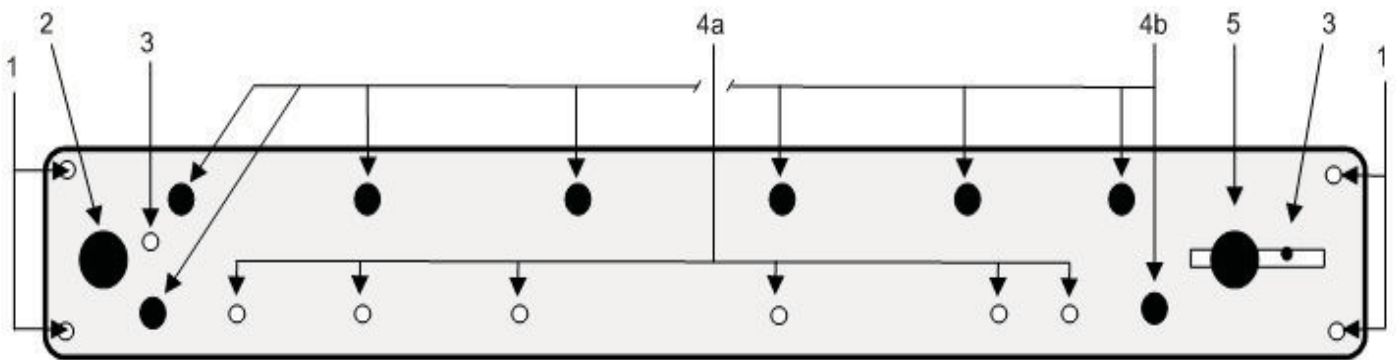

Fig. 26a — Conveyor Side View (blank side)

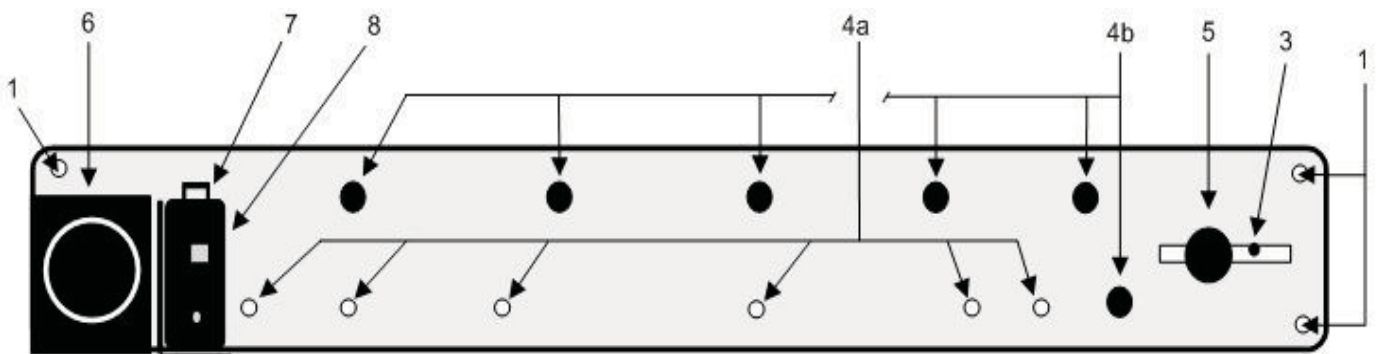

Fig. 26b — Conveyor Side View (drive side).

BELT TENSIONING AND TRACKING

A. TO TENSION THE BELT

1. Position the conveyor to easily access both sides of the idler end (opposite the drive end).
2. Install the belt tensioning tool with hook connector over the belt tension lock screw washers. (See arrows, Fig. 27.)
3. Turn the knurled adjustment knob on the tensioning tool clockwise until the tensioning cross brace is against the conveyor siderail ends.
4. Using a 3/16" hex key loosen both the belt tension lock screws.
5. To tension belt: Tighten (clockwise) the tensioning tool knurled adjustment knob in 1/2- turn increments until hand tight.

CAUTION: Do not over-tension belt. Hand-tighten the adjustment knob. Use only that force which can be applied by thumb and forefinger on the tensioning tool adjustment knob.

6. Using the 3/16" hex key, tighten both tension belt adjustment screws until key handle flexes approximately 1/2 inch.
7. Proceed to Step B for the belt tracking procedure.

B. TO TRACK THE BELT

Mini-Mover conveyors utilize precision crowned pulleys for superior belt tracking. Belt tension and tracking are initially set at the factory prior to shipment. Over time, belt tracking may require adjustment in the field as follows.

1. Perform the belt tensioning procedure above.
2. Start the conveyor and run the belt without load for 30 seconds. While facing the idler (non-motor) end of the conveyor, observe the belt tracking position.
 - a. If the belt is correctly center-tracking and needs no adjustment, proceed to Step 4 below.
 - b. If the belt tracks to either left or right, loosen the belt tension lock screw on the same side to which the belt is tracking.
3. To adjust the belt tracking, tighten (clockwise) the tensioning tool knurled adjustment knob in about 1/16-turn increments until the belt is center tracking. See Fig. 27 below.
4. Run the conveyor an additional 1-2 minutes to assure the belt continues to center track. Make any final adjustments required, per Fig. 27 below.
5. Using a 3/16" short handle hex key, tighten the belt tension lock screw until the wrench handle flexes approximately 1/2 inch.
6. Remove the tension tool by loosening the adjustment knob. (This tool may be stored between uses; it does not need to remain attached to the conveyor.)

The conveyor is now ready to return to service.

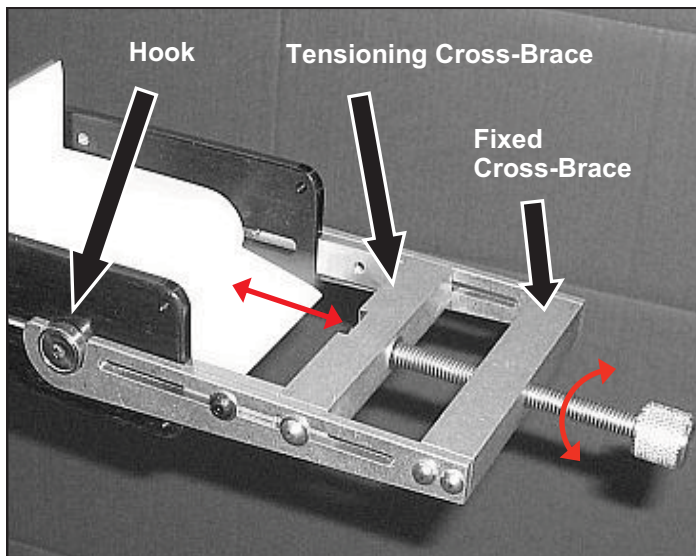

Fig. 27
Tensioning & tracking tool
(for belt widths \leq 10 in.)

CUSTOMER SERVICE

Mini-Mover Conveyors offers you customer service and support throughout all phases of the sale, delivery, setup and ongoing maintenance for the life of your Uni-Mate® product. Call or email us if you need any assistance, such as the following areas.

- New Uni-Mate® delivery — to report damage during shipment
- New Uni-Mate® setup support or operating questions
- Troubleshooting assistance
- Add-on accessories or options for your Uni-Mate®
- Spare parts for your stock bin
- Returns or exchanges
- Applications consultation

Please note that for returns or exchanges, you will need to contact us for a Returned Goods Authorization (RGA) before shipping anything back to the factory. The RGA gives you more detailed shipping instructions and allows us to track your items for proper credit or exchange.

If you have a question or need that is specific to your conveyor, please have the Serial Number of the unit on hand when contacting us. Each conveyor is built to order, and the serial number allows us to identify each component and manufacturing note regarding your unit and its service history.

Mailing and Shipping Address:

Mini-Mover Conveyors
division of Whipple Enterprises
21150 Shake Ridge Rd.
Volcano, CA 95689

Customer Service:

Phone: 800-586-4585

Fax: 866-900-5124

Email: service@mini-mover.com

PRODUCT WARRANTY

MINI-MOVER CONVEYORS
div. of Whipple Enterprises, Inc.

Uni-Mate® (Table & Conveyor product) Limited Lifetime Warranty

Warranty Service Provided

Whipple Enterprises warrants its Mini-Mover Uni-Mate® product against defects in material or workmanship for the usable lifetime of the product following the original date of purchase. Whipple Enterprises' responsibility under this warranty is limited to the repairing or replacing, at its sole option, any defective product. The warranty begins on the date of the original purchase from the factory for its usable lifetime and is not transferrable to any third parties. This lifetime warranty is voided once the original purchaser sells or rents the unit, the unit has been significantly abused or has been used for purposes beyond the intended parameters of conveyor design and operation. However, in cases where ownership of the unit should transfer to a third party, that party may contact Whipple Enterprises for consideration of possible transfer of this warranty, on a case-by-case basis.

This item is purchased "as-is." There are no warranties that extend beyond the description on the face thereof. Whipple Enterprises makes no other warranty. Whipple Enterprises specifically disclaims any implied warranties, including warranties of merchantability and fitness for any particular purpose. In no event shall Whipple Enterprises be liable for direct, indirect, special or consequential damages.

In addition to the foregoing, Whipple Enterprises specifically disclaims and not honor any warranties with respect to the purchasers and corporation of this product as a component of the purchaser's product sold to other users as an integrated unit. Whipple will only be responsible, under its warranty, for the performance of its product only, and not for any other product in which this product is incorporated. Additionally, the purchaser of this product agrees to hold Whipple harmless and defend and indemnify Whipple Enterprises should any claims be made against Whipple for the use of any such product sold to an end user that incorporated this product in this fashion.

Warranty Service Not Provided

This warranty does not cover normal wear and tear of parts as a result of normal operation over time, nor damage resulting from accident, misuse, abuse, improper installation, unauthorized modification and/or loss of parts. This warranty is voided if any unauthorized person opens, alters, or repairs the unit beyond that which is directed in this manual.

Obtaining Service under Warranty

You must obtain a Return Goods Authorization (RGA) number from Whipple Enterprises' customer service. The product must be returned to Whipple Enterprises with transportation charges prepaid and must be accompanied by a brief description of the problem encountered and proof of purchase.

Product Return Policy

The Return Goods Authorization (RGA) number is required for return of any product to Whipple Enterprises. This number must be clearly visible on the packing carton. Please retain the original shipping carton and packing materials. The original shipping carton is the best shipping container for returning your unit, if required.

UNI-MATE® OWNER'S MANUAL

Important Notes for your Service Records:

Date of Installation: _____

Table S/N _____

Conveyor S/N _____

Purchased from: _____
(if other than factory-direct)

*Read instructions for unpacking your Uni-Mate®
on the inside front cover of this manual.*

*Read assembly and safety instructions
before using.*

**MINI-MOVER
UNI-MATE®**

MADE IN THE U.S.A.

Visit us on the web at www.mini-mover.com